

MAINTENANCE MANUAL LOGIC BOARD 19D901690G11 FOR MVS/MCS/TMX-8712/TMX-8310

TABLE OF CONTENTS

	<u>Page</u>
DESCRIPTION	Front Cover
CIRCUIT ANALYSIS	Front Cover
SERVICE NOTES	1
IC DATA	2
PARTS LIST	4
OUTLINE DIAGRAM	4
SCHEMATIC DIAGRAM	5

DESCRIPTION

The Logic Board controls the operation of the MVS, MCS, TMX-8712, and TMX-8310 radios. It is located in the bottom of the frame assembly beneath the Audio Board. Refer to the combination manual for a complete mechanical layout.

The Logic Board contains a microprocessor and associated memory circuits which include an EPROM for controlling the processor and a programmable "personality" EEPROM to store customer frequencies, tones, and options. Programmable data is entered using an IBM compatible personal computer and an RS-232 interface. Refer to the programming manual for programming instructions.

The Logic Board also contains a +5 VDC regulator (U705) for the integrated circuits on the board and the circuitry for the horn-relay.

Refer to Figure 1 for a block diagram of the Logic board. Refer to the Table of Contents for IC data sheets with pin out information on integrated circuits.

CIRCUIT ANALYSIS

MICROPROCESSOR

Microprocessor U701 (INTEL 8032) is an 8-bit processor that performs the logical functions to provide the control signals required in the radio. An external 11.0592 MHz crystal (Y701) is used for the clock. This microprocessor controls the following:

- Synthesizer
- Transmit circuit
- Decoding of system tones
- Generation of system tones
- Transmitter and receiver audio mute gates

The input line, PTT, CH SEL 0, CH SEL 1, and MONITOR are pulled high to +5 volts through 50k ohm resistors inside the microprocessor. The lines are grounded by the switches in the control head. Diodes D701-D708 on these lines protect the microprocessor from static discharges.

Serial data at a 300 baud rate is used for communications between the microprocessor and handset.

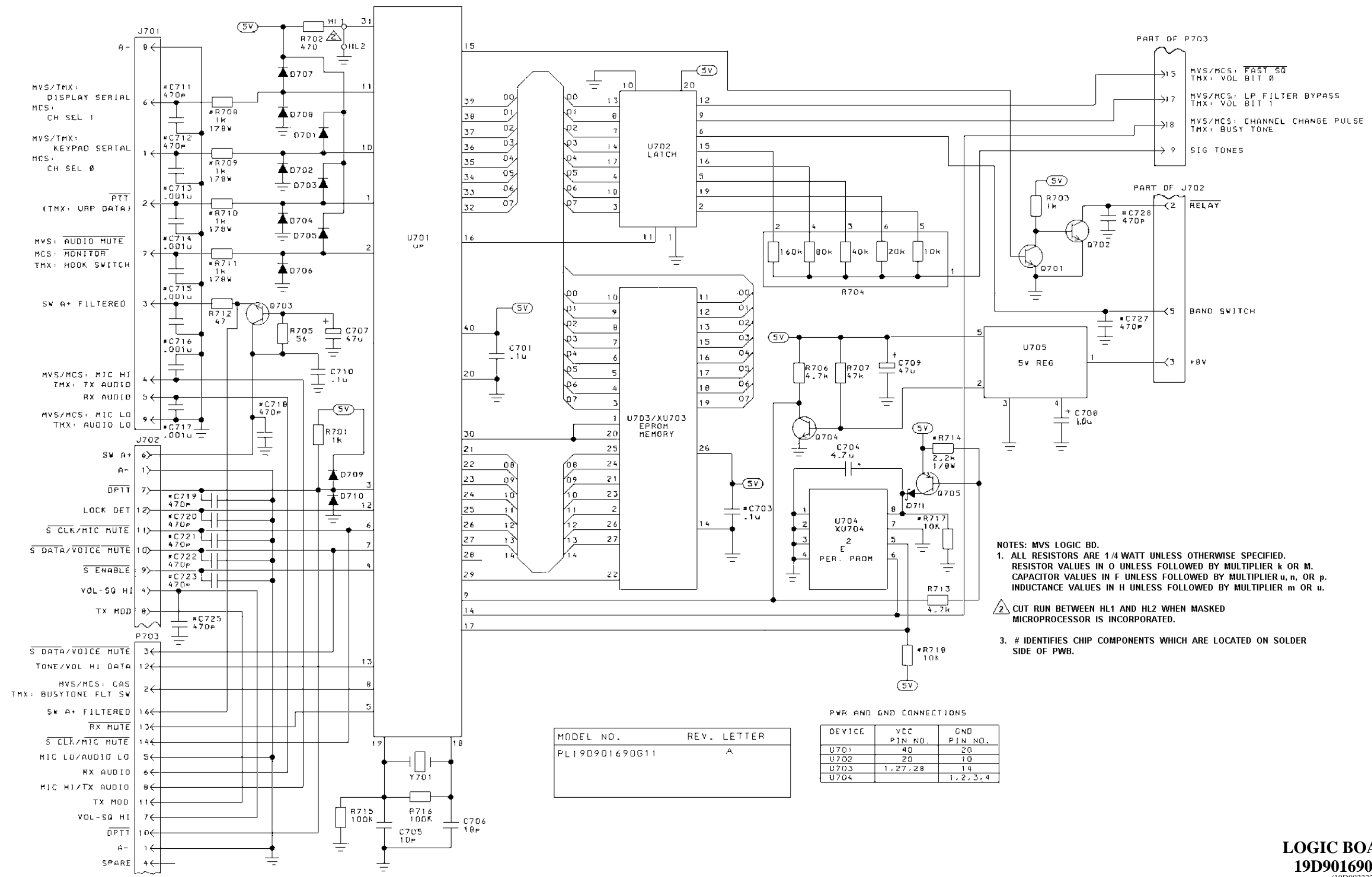

- NOTES: MVS LOGIC BD.
1. ALL RESISTORS ARE 1/4 WATT UNLESS OTHERWISE SPECIFIED. RESISTOR VALUES IN O UNLESS FOLLOWED BY MULTIPLIER k OR M. CAPACITOR VALUES IN F UNLESS FOLLOWED BY MULTIPLIER u, n, OR p. INDUCTANCE VALUES IN H UNLESS FOLLOWED BY MULTIPLIER m OR u.
 2. CUT RUN BETWEEN HL1 AND HL2 WHEN MASKED MICROPROCESSOR IS INCORPORATED.
 3. # IDENTIFIES CHIP COMPONENTS WHICH ARE LOCATED ON SOLDER SIDE OF PWB.

MODEL NO. REV. LETTER
 PL19D901690G11 A

PWR AND GND CONNECTIONS

DEVICE	VCC P/N NO.	GND P/N NO.
U701	40	20
U702	20	10
U703	1, 27, 28	14
U704		1, 2, 3, 4

LOGIC BOARD
19D901690G11
 (19D90332, Rev. 1)

LOGIC BOARD
19D901690G1

SYMBOL	PART NUMBER	DESCRIPTION
----- CAPACITORS -----		
C701	19A700121P106	Ceramic: 0.1 μF ±20%, 50 VDCW.
C703	19A702052P26	Ceramic: 0.1μF ±10%, 50 VDCW
C704	19A701534P6	Tantalum: 4.7 μF ±20%, 35 VDCW.
C705	19A700235P13	Ceramic: 10 pF ±5%, 50 VDCW.
C706	19A700235P16	Ceramic: 18 pF ±5%, 50 VDCW.
C707	19A704879P2	Electrolytic: 47 μF ±20%, 16 VDCW.
C708	19A701534P4	Tantalum: 1 μF ±20%, 35 VDCW.
C709	19A701534P9	Tantalum: 47 μF ±20%, 6.3 VDCW.
C710	19A700121P106	Ceramic: 0.1 μF ±20%, 50 VDCW.
C711 and C712	19A702061P77	Ceramic: 470 pF ±5%, 50 VDCW, temp coef 0 ±30 PPM.
C713 thru C717	19A702052P5	Ceramic: 1000 pF ±10%, 50 VDCW.
C718 thru C720	19A702061P77	Ceramic: 470 pF ±5%, 50 VDCW, temp coef 0 ±30 PPM.
C721 thru C723	19A702061P61	Ceramic: 100 pF ±5%, 50 VDCW, temp coef 0 ±30 PPM.
C725	19A702061P77	Ceramic: 470 pF ±5%, 50 VDCW, temp coef 0 ±30 PPM.
C727 and C728	19A702061P77	Ceramic: 470 pF ±5%, 50 VDCW, temp coef 0 ±30 PPM.
----- DIODES -----		
D701 thru D710	19A700028P1	Silicon: 75 mA, 75 PIV; sim to 1N4148.
D711	19A700047P3	Silicon: 100 mW; sim to 1N6263.
----- JACKS -----		
J701	19B209727P40	Connector, Plug; sim to AMP 750077-1.
J702	19A704779P11	Connector; sim to Molex 22-17-2122.
----- PLUGS -----		
P703	19A704874P1	Connector: sim to: Elco 00-9021-18-12-00-339.
----- TRANSISTORS -----		
Q701	19A700023P2	Silicon, NPN: sim to 2N3904.
Q702 and Q703	19A702503P2	Silicon, NPN: sim to 2N4401.
Q704	19A700023P2	Silicon, NPN: sim to 2N3904.
Q705	19A700022P2	Silicon, PNP: sim to 2N3906.

* COMPONENTS, ADDED, DELETED OR CHANGED BY PRODUCTION CHANGES

SYMBOL	PART NUMBER	DESCRIPTION
----- RESISTORS -----		
R701	H212CRP210C	Deposited carbon: 1K ohms ±5%, 1/4 w.
R702	H212CRP147C	Deposited carbon: 470 ohms ±5%, 1/4 w.
R703	H212CRP210C	Deposited carbon: 1K ohms ±5%, 1/4 w.
R704	19A704885P5	Resistive Network: ±2%, 1/8 w.
R705	H212CRP056C	Deposited carbon: 56 ohms ±5%, 1/4 w.
R706	H212CRP247C	Deposited carbon: 4.7K ohms ±5%, 1/4 w.
R707	H212CRP347C	Deposited carbon: 47K ohms ±5%, 1/4 w.
R708 thru R711	19B800607P102	Metal film: 1K ohms ±5%, 1/8 w.
R712	H212CRP047C	Deposited carbon: 47 ohms ±5%, 1/4 w.
R713	H212CRP247C	Deposited carbon: 4.7K ohms ±5%, 1/4 w.
R714	19B800607P222	Metal film: 2.2K ohms ±5%, 1/8 w.
R715 and R716	19B800607P104	Metal film: 100K ohms ±5%, 1/8 w.
R717 and R718	19B801251P103	Metal film: 10K ohms ±5%, 1/10 w.
----- INTEGRATED CIRCUITS -----		
U701		INTEL 8032; HMOS 8-bit microprocessor.
U702	19A704380P12	Digital: CMOS Octal Tri-State Data Flip-Flop; sim to 74HC374.
U703	344A3608P1	Digital, EPROM: 87C257, CMOS, 8K byte.
U704	19A704724P3	Digital, EEPROM. 512 x 8-bit; X24C04; CMOS Version.
U705	19A704970P1	Linear: 5 Volt Regulator with Reset Output; sim to SGS L387.
----- SOCKETS -----		
XU701	19A700156P5	Socket, IC: 40 Pins, Tin Plated.
XU703	19A700156P3	Socket, IC: 28 Pins, Tin Plated.
XU704	19A700156P15	Socket, IC: 8 Pins, Tin Plated.
----- CRYSTALS -----		
Y701	19A702511G15	Quartz: 11.059200 MHz.

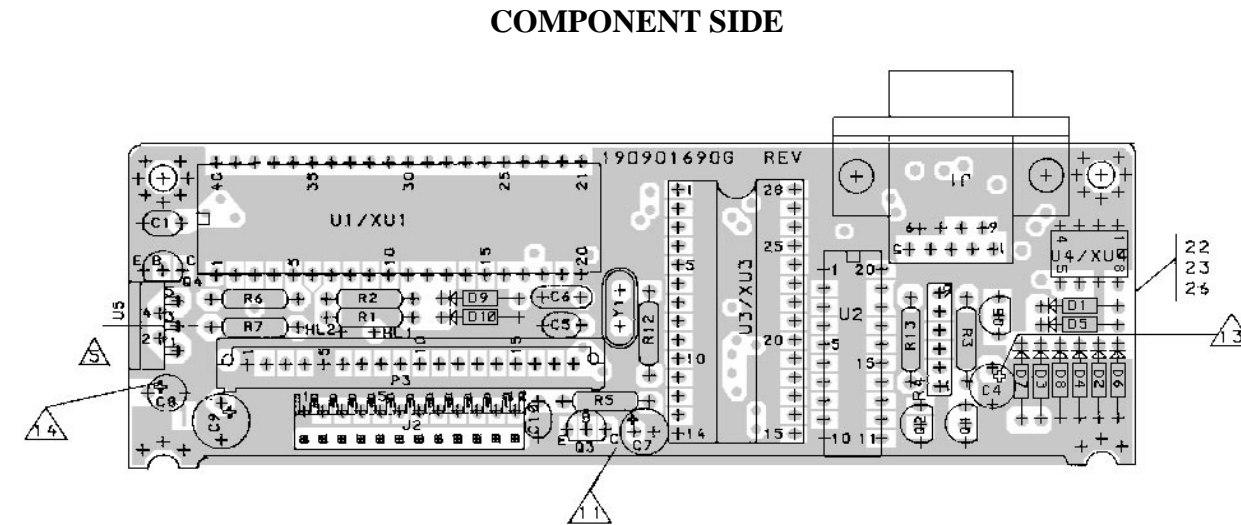

COMPONENT SIDE

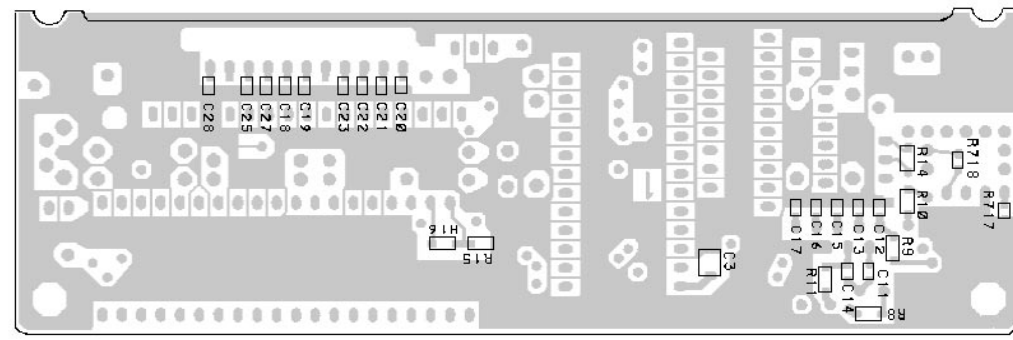

SOLDER SIDE

VIEW FROM BACK OF BOARD

- △1 THE (+) LEAD OF C7 IS THE LONGEST OF THE TWO
- 12. PIN 1 OF R4 IDENTIFIED BY DOT. COLOR STRIPE. VENDOR'S LOGO OR NOTCH
- △3 THE + SIDE OF C4 IS TO BE TOWARD J1 (AS INDICATED).
- △4 THE + SIDE OF C8 IS TO BE TOWARD THE BOARD EDGE (AS INDICATED).

LOGIC BOARD
19D901690G11
(19D901690, Sh. 4, Rev. 1)
(19D903331, THIRD LAYER, Rev. 1)
(19D903331, FOURTH LAYER, Rev. 1)



U702
OCTAL TRI-STATE D FLIP-FLOP
19A704380P12

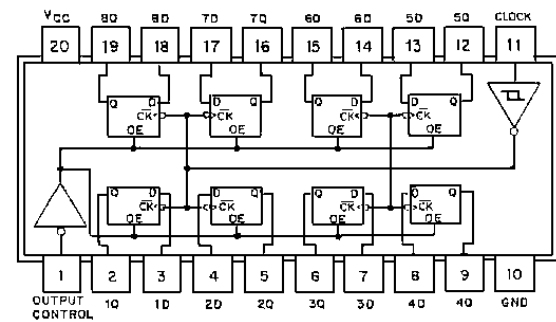
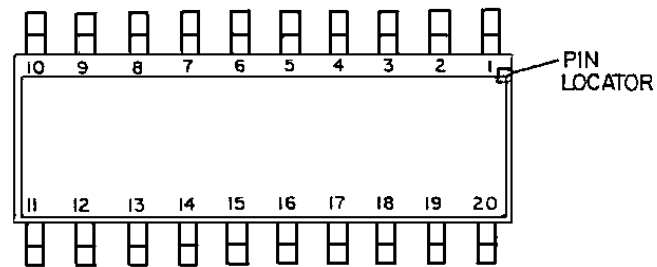

TRUTH TABLE

OUTPUT CONTROL	CLOCK	DATA	OUTPUT
L	↑	H	H
L	↑	L	L
L	L	X	Q ₀
H	X	X	Z

H = HIGH LEVEL, L = LOW LEVEL
 X = DON'T CARE
 ↑ = TRANSITION FROM LOW-TO-HIGH
 Z = HIGH IMPEDANCE STATE
 Q₀ = THE LEVEL OF THE OUTPUT BEFORE STEADY STATE INPUT CONDITIONS WERE ESTABLISHED.

U704
512 X 8-BIT EEPROM
19A704724P3

PIN CONFIGURATION

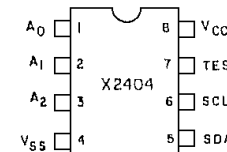

FUNCTION DIAGRAM

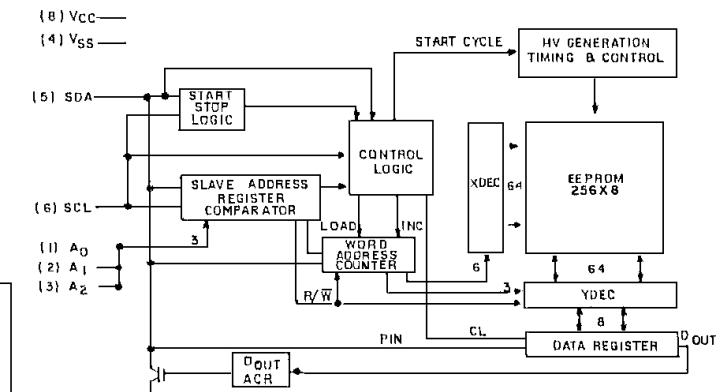

- 1 A₀ → TO V_{SS}
- 2 AND 3 A AND A ADDRESS INPUTS
- 4 V_{SS}
- 5 SDA SERIAL DATA — I²C BUS
- 6 SCL SERIAL CLOCK — BUS
- 7 TEST INPUT — TO V_{SS}
- 8 V_{CC}

U703
CMOS 8K BYTE EPROM
344A3608P1

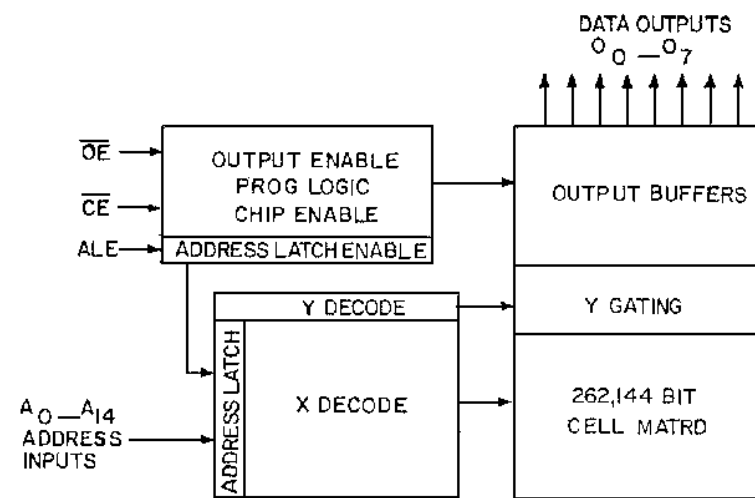
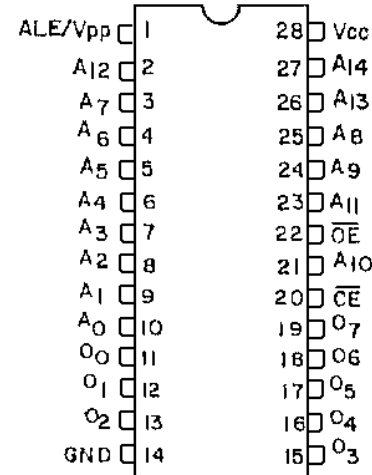

U705
+5 VOLT REGULATOR
19A704970P1

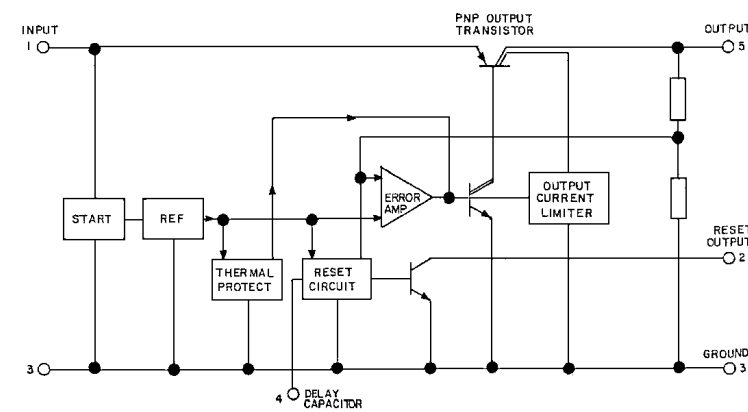
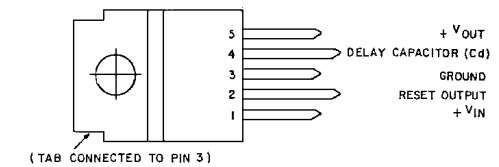

SERVICE NOTES

If a faulty Logic Board is suspected, it may be useful to confirm this by substitution of a known good board.

DC CHECKS

Power for the Logic Board is supplied by the 8 volts on J702, Pin 3. This comes from the transmitter regulator U102.

1. Check for +5 volts ± 0.25 volts on U705, Pin 5.
2. Check Power-On Reset on U701, Pin 9 (see Figure 2). If not present, check regulator U705, Pin 2 and transistor Q704.

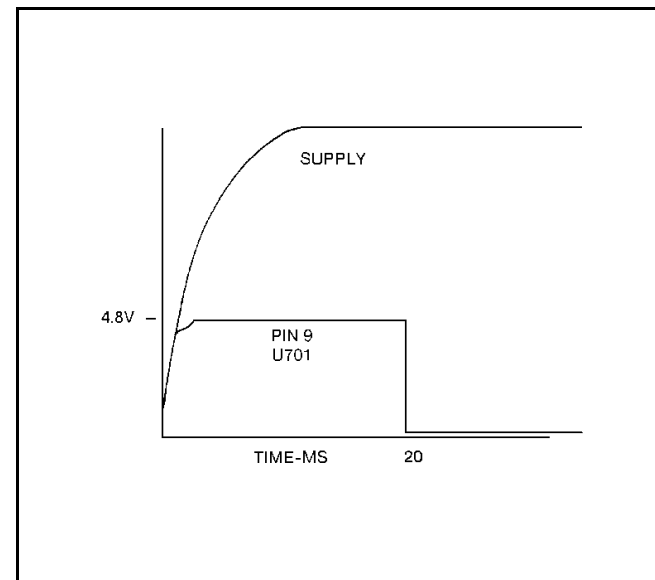

Figure 2 - Reset Waveform

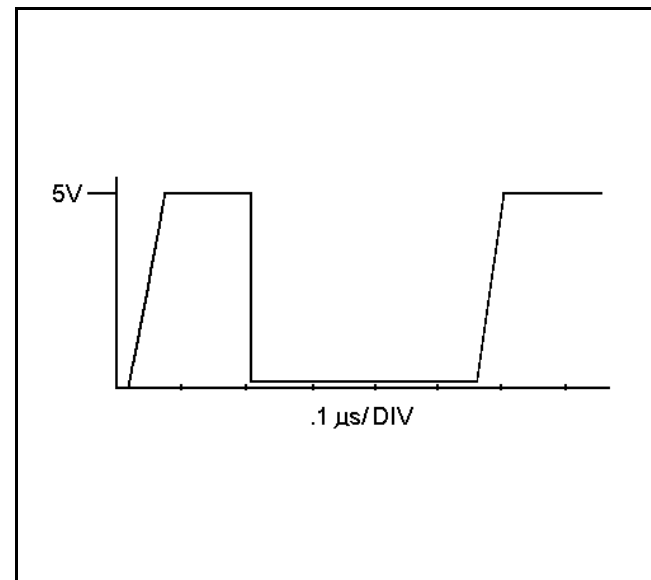
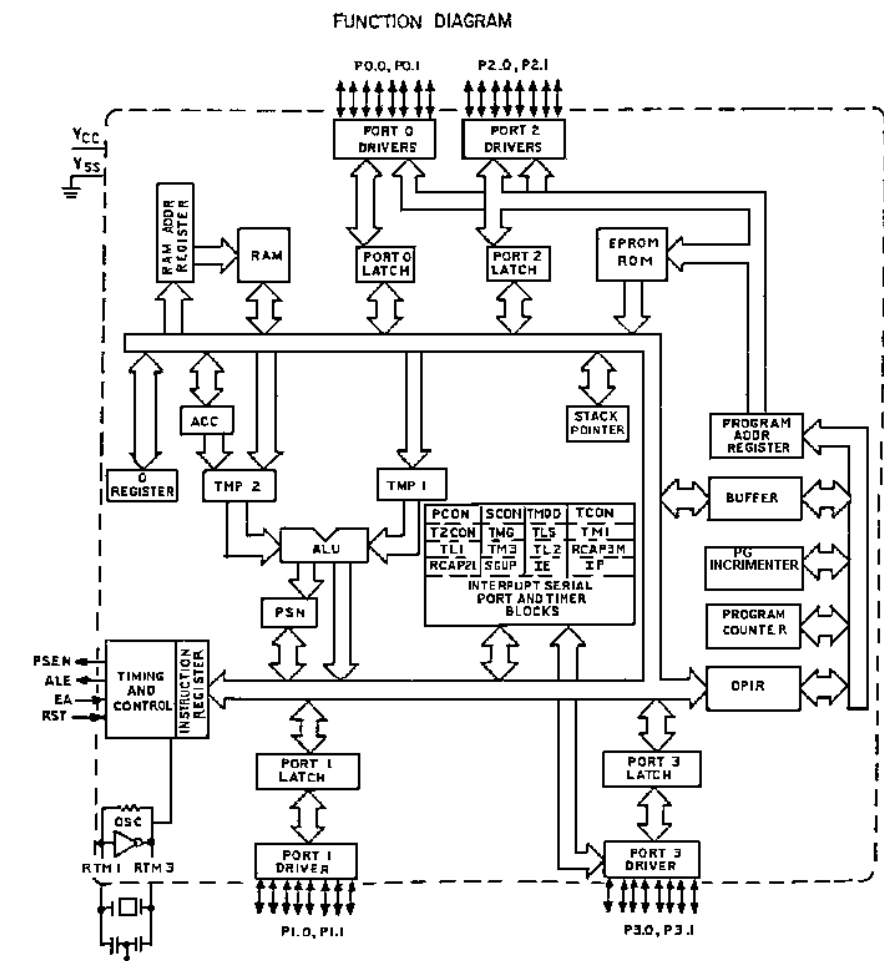
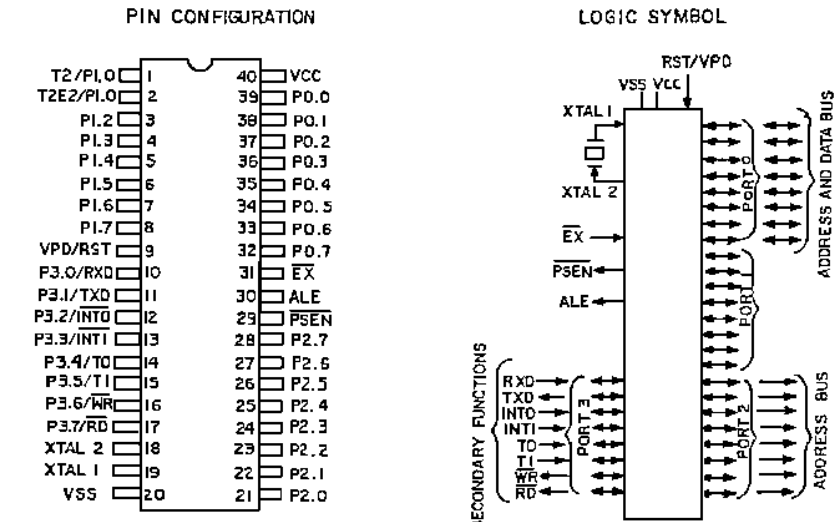

Figure 3 - ALE Clock

3. Check for oscillator activity by examining the ALE clock on U701, Pin 30 (see Figure 3). If not present, examine the system clock on U701, Pin 18 (5 volts pp at 11.059 MHz). The presence of the system clock, but no ALE may indicate a bad U701. If the system clock is not present, suspect Y701 and related components.
4. All output lines from the microprocessor are pulled high to +5 volts through 50k ohm resistors inside the microprocessor. If a line is high, you may ground that pin and monitor the results. However, if a line is low, the line may not be forced to +5 volts.

**U701
HMOS 8-BIT MICROPROCESSOR
19A703714P1**



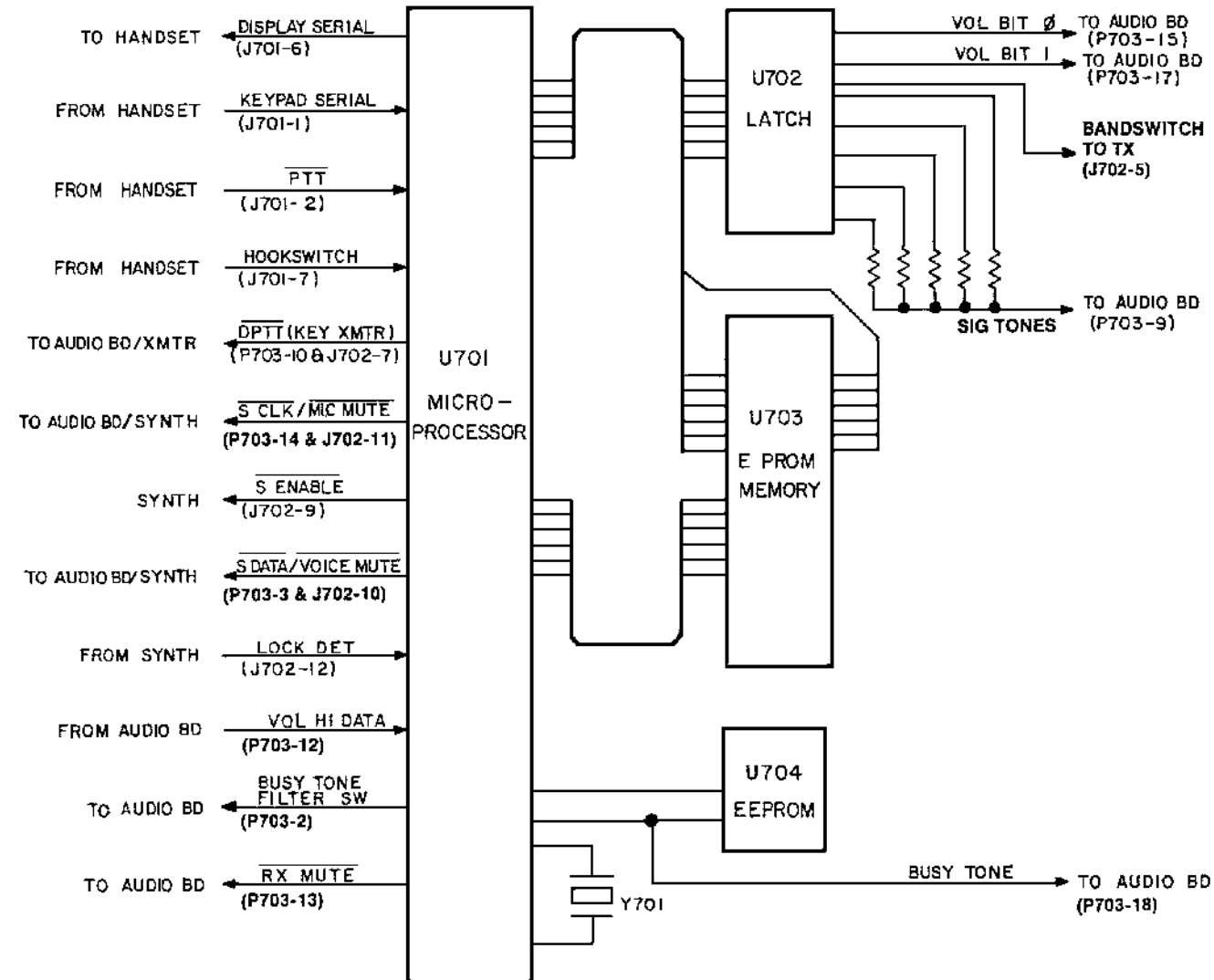

Figure 1 - Logic Board Block Diagram

ERASABLE PROM (EPROM)

EPROM U703 is a CMOS 8-kilobyte device with an internal address latch. All information required by the microprocessor for system operation resides in this EPROM. The EPROM contains both the customer system software and the test software.

The software version programmed into the device determines the radio option used. The TMX-8712 uses the duplex software and the TMX-8310 uses the dispatch software.

ELECTRICALLY ERASABLE PROM (EEPROM)

EEPROM U704 is a 512 x 8-bit memory device, designated the "personality" PROM. This personality PROM stores all customer required information including frequencies, tones and options. The EEPROM also retains the status of all radio functions (channel selection, volume setting, scan channel list, and scan on-off functions) to return to the same mode of operation after power is removed from the radio.

The EEPROM can be conveniently programmed without any need for opening up the radio. This is accomplished through J701 on the Logic Board.

DC power for U704 is switched by transistor Q705. During the active high reset pulse to the microprocessor, Q705 removes +5 VDC from U704 to reset the EEPROM. See the voltage regulator description below.

LATCH

Latch U702 is a CMOS, 3-state, non-inverting, D Flip-Flop with the following functions:

- To control the volume bit "0" and volume bit "1" on the Audio Board.
- To activate the band switch on the RF Board.
- To act as a digital-to-analog converter (DAC) by generating sine wave signalling tones using ladder resistor network R704.

HORN RELAY

The horn relay circuit consists of NPN buffer transistor Q701 and NPN relay driver transistor Q702. The horn relay is activated by the microprocessor by applying a 1 kHz, 5 volt square wave signal to the base of Q701. The circuit is capable of handling up to 150 milliamperes from an externally connected relay coil.

VOLTAGE REGULATOR

Voltage regulator U705 supplies a regulated +5 volts DC to the microprocessor, the EPROM, the EEPROM, and the latch circuit. A reset circuit is built into U705 to provide the microprocessor with a reset signal required during its power-up routine. Regulated +8 volts DC is supplied to regulator U705 from the 8-volt regulator U102 located on the RF board.

BATTERY VOLTAGE FILTER

Transistor circuit Q703 is a filter circuit for the A+ battery voltage. This circuit is used to reduce "alternator whine" interference. The filtered A+ (13 volts) is used in the handset and on the audio board.

CAUTION

The CMOS Integrated Circuit devices used in this equipment can be destroyed by static discharges. Before handling one of these devices, the serviceman should discharge himself by touching the case of a bench test instrument that has a three-prong power cord connected to an outlet with a known good earth ground. When soldering or desoldering a CMOS device, the soldering iron should also have a 3-prong power cord connected to an outlet with a known good earth ground. A battery-operated soldering iron may be used in place of the regular soldering iron.